

Pressure sequence valve, direct operated

RE 26076/04.07
Replaces: 02.03

1/6

Type DZ 6 DP

Nominal size 6
Series 5X
Maximum operating pressure 315 bar
Maximum flow 60 l/min

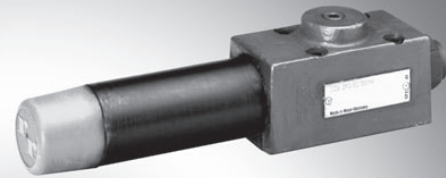

K 4297-9

Overview of contents

Contents	Page
Features	1
Order code	2
Preferred types	2
Symbols	2
Function, section	3
Technical data	4
Characteristic curves	4
Unit dimensions	5

Features

- For subplate mounting
- Connection location to DIN 24340 form A (without locating bore), (standard)
- Connection location to ISO 4401-03-02-0-05 (with locating bore), (ordering code .../60)
- Subplates see catalogue sheet RE 45052 (separate order)
- 5 pressure stages
- 4 adjustment elements, optional:
 - Rotary knob
 - Set screw with hexagon and protective cap
 - Lockable rotary knob with scale
 - Rotary knob with scale
- Check valve, optional

Informationen zu lieferbaren Ersatzteilen:
www.boschrexroth.com/spc

Order code

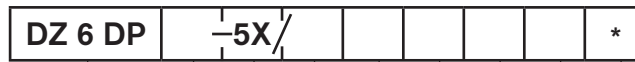

Pressure sequence valve NG6, direct operated

Adjustment element

- Rotary knob = 1
- Set screw with hexagon and protective cap = 2
- Lockable rotary knob with scale ¹⁾ = 3
- Rotary knob with scale = 7

Series 50 to 59 = 5X
 (50 to 59: unchanged installation and connection dimensions)

- Max. sequence pressure 25 bar = 25
- Max. sequence pressure 75 bar = 75
- Max. sequence pressure 150 bar = 150
- Max. sequence pressure 210 bar = 210
- Max. sequence pressure 315 bar = 315 ²⁾

- ¹⁾ H-key with Material No. **R900008158** is included within the scope of supply.
- ²⁾ Only with adjustment element „2“ and without check valve
- ³⁾ Locating pin ISO 8752-3x8-St, Material No. **R900005694** (separate order)

Further details in clear text

No code = without locating pin hole
 .../60 ³⁾ = with locating pin hole

Seal material
 No code = NBR seals
 V = FKM seals
 (other seals on request)

⚠ Attention!

The compatibility of the seals and pressure fluid has to be taken into account!

No code = with check valve
 M = without check valve

No code = Internal pilot oil supply, internal leakage oil drain
 X = External pilot oil supply, internal leakage oil drain
 Y = Internal pilot oil supply, external leakage oil drain
 XY = External pilot oil supply, external leakage oil drain

Standard types

Type	Material number
DZ 6 DP2-5X/25Y	R900403077
DZ 6 DP2-5X/75Y	R900481060
DZ 6 DP2-5X/150Y	R900481061
DZ 6 DP2-5X/210Y	R900481062
DZ 6 DP2-5X/315YM	R900513984

Preferred types and standard components are highlighted in the RPS (Standard Price list).

Symbols

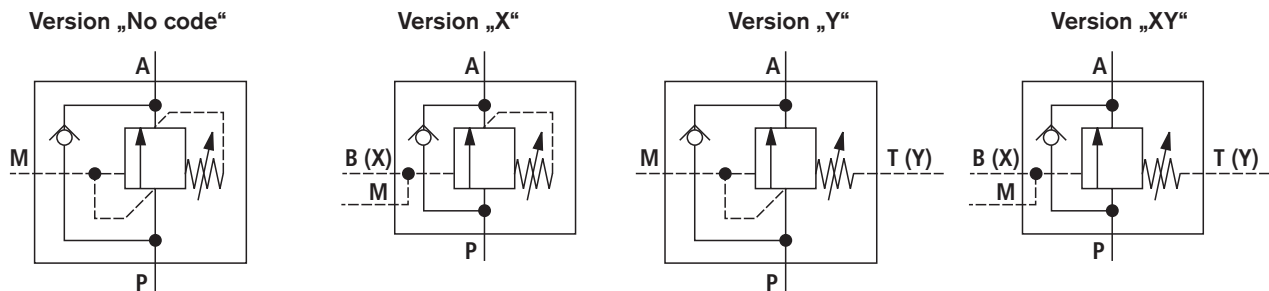

Function, section

The valve type DZ 6 DP is a direct operated pressure sequence valve. It is used for the pressure dependent connection of a second system. The setting of the sequence pressure is via the adjustment element (4).

The compression spring (3) holds the control spool (2) in its initial position, the valve is closed. The pressure in port P is applied to the piston area of the control spool (2) via the control line (6) at the opposite side to the spring (3).

When the pressure in port P reaches the set value of the spring (3), then the control spool (2) is moved to the left and the connection P to A is opened. The system connected to port A is connected without a pressure decrease occurring in port P.

The control signal originates internally via the control line (6) from port P or externally via port B (X).

Depending on the use of the valve the leakage oil drain is externally via port T (Y) or internally via A.

⚠ Attention!

With **internal** leakage oil drain the **set** opening pressure **increases** by the pressure present in port "A".

For the free return of the pressure fluid from port A to port P a check valve (5) may optionally be installed.

A pressure gauge port (1) enables the monitoring of the sequence pressure set at the valve.

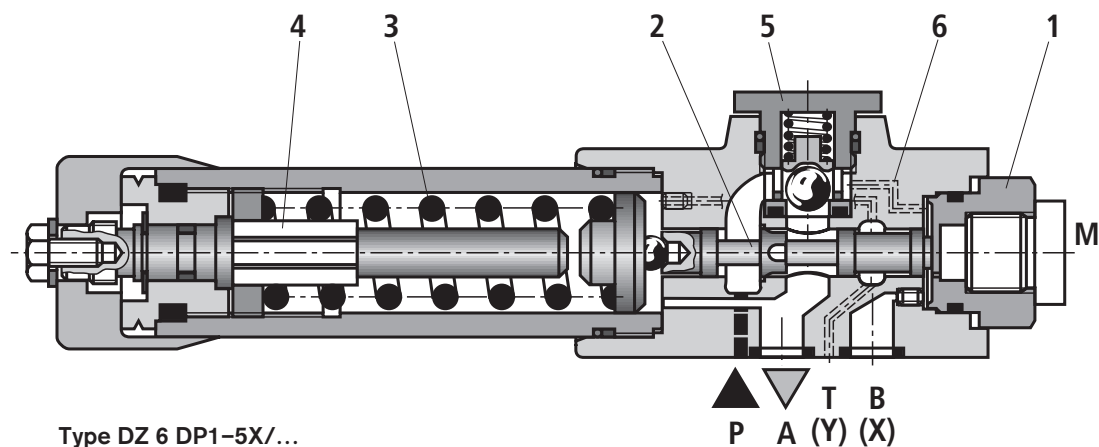

Type DZ 6 DP1-5X/...

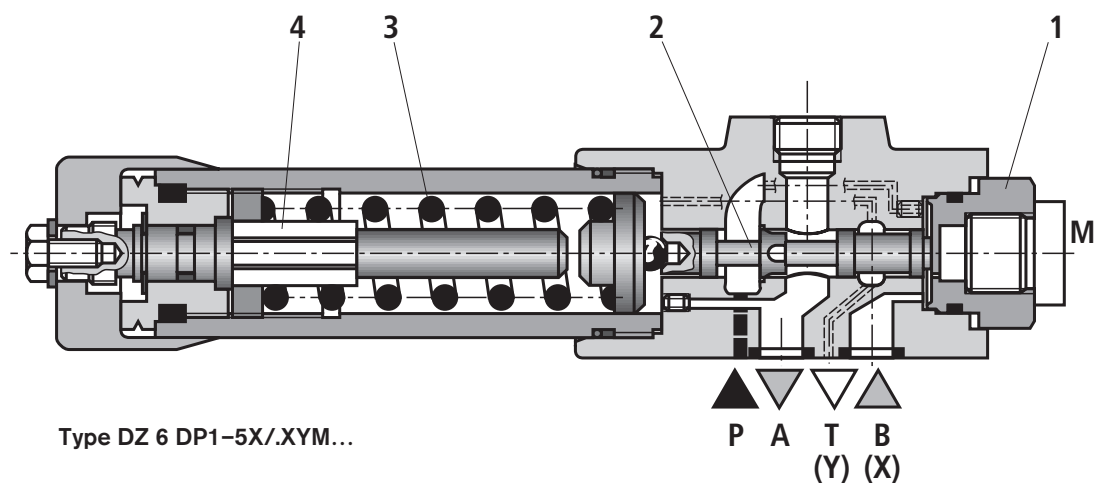

Type DZ 6 DP1-5X/.XYM...

Technical data (for applications outside these parameters, please consult us!)**General**

Weight	kg	Approx. 1.2
Installation		Optional
Ambient temperature range	°C	-30 to +80 (NBR seals) -20 to +80 (FKM seals)

Hydraulic

Maximum operating pressure	- Ports P, A, B (X)	bar	315
	- Ports T (Y)	bar	160
Maximum sequence pressure (adjustable)		bar	25; 75; 150; 210; 315
Maximum flow		l/min	60
Pressure fluid			Mineral oil (HL, HLP) to DIN 51524 ¹⁾ ; Fast bio-degradable pressure fluids to VDMA 24568 (also see RE 90221); HETG (rape seed oil) ¹⁾ ; HEPG (polyglycols) ²⁾ ; HEES (synthetic ester) ²⁾ ; other pressure fluids on request
Pressure fluid temperature range		°C	-30 to +80 (NBR seals) -20 to +80 (FKM seals)
Viscosity range		mm ² /s	10 to 800
Max. permissible degree of contamination of the hydraulic fluid – cleanliness class to ISO 4406 (c)			Class 20/18/15 ³⁾

¹⁾ Suitable for NBR and FKM seals

²⁾ **Only** suitable for FKM seals

³⁾ The cleanliness class stated for the components must be adhered to in hydraulic systems. Effective filtration prevents

faults from occurring and at the same time increases the component service life.

For the selection of filters see catalogue sheets RE 50070, RE 50076, RE 50081, RE 50086, RE 50087 and RE 50088.

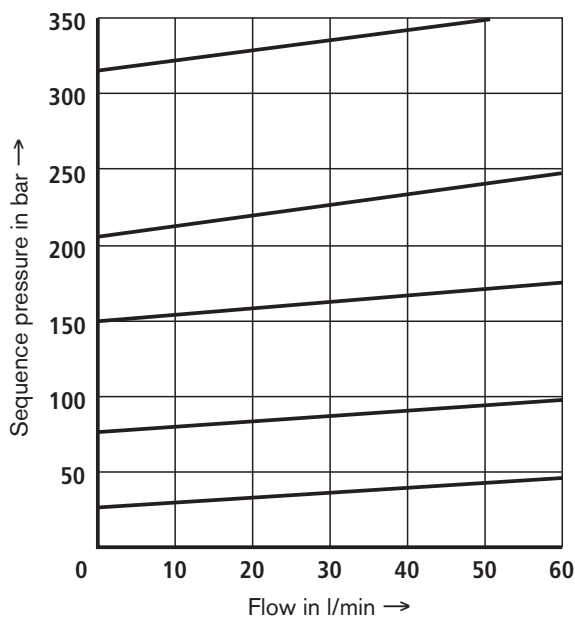
Characteristic curves (measured with HLP46, $\vartheta_{oil} = 40\text{ °C} \pm 5\text{ °C}$)**p-q_v-characteristic curves**

The characteristic curves are valid for the output pressure = zero over the entire flow range

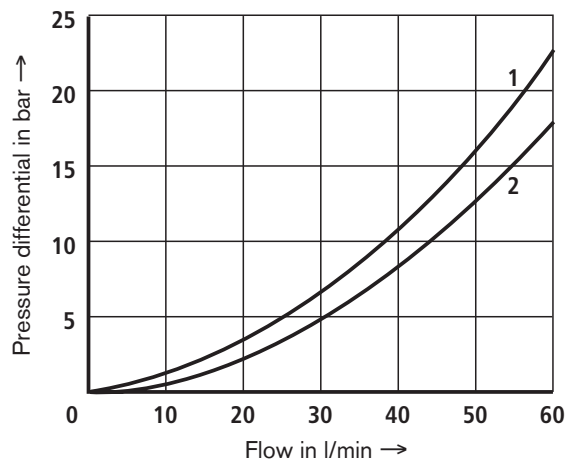
Δp-q_v-characteristic curves

1 via check valve, flow from A to P

2 P to A

Unit dimensions (dimensions in mm)

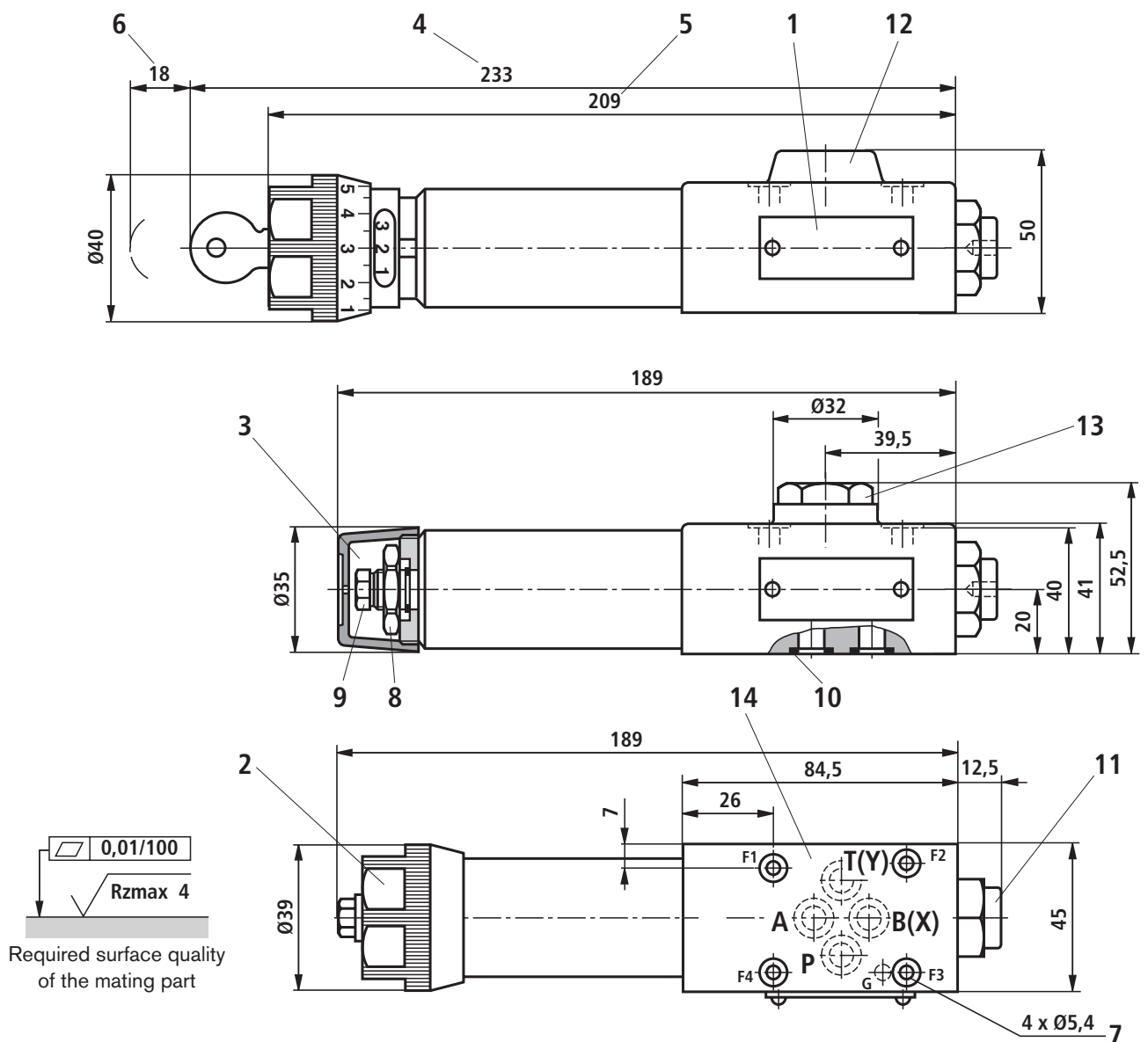

- 1 Name plate
- 2 Adjustment element „1“
- 3 Adjustment element „2“
- 4 Adjustment element „3“
- 5 Adjustment element „7“
- 6 Space required to remove the key
- 7 Valve fixing holes
- 8 Locknut 24A/F
- 9 Hexagon 10A/F
- 10 Same seal rings for ports A, B(X), P, T(Y)
- 11 Pressure gauge connection G1/4; 12 deep; internal hexagon 6A/F
- 12 Without check valve
- 13 With check valve

- 14 Connection location to DIN 24340 Form A (without locating bore), or ISO 4401-03-02-0-05 (with locating bore for locating pin ISO 8752-3x8-St, Material No. **R900005694**, order separately)

Subplates to data sheet RE 45052 (order separately)

- | | |
|-------------------------|-----------------|
| (without locating bore) | G 341/01 (G1/4) |
| | G 342/01 (G3/8) |
| | G 502/01 (G1/2) |
| (with locating bore) | G 341/60 (G1/4) |
| | G 342/60 (G3/8) |
| | G 502/60 (G1/2) |

Valve fixing screws (order separately)
4 socket head cap screws (SHCS)
ISO 4762 - M5 x 50 - 10.9-fIZn-240h-L
friction coefficient $\mu_{\text{total}} = 0.09$ bis 0.14 ,
tightening torque $M_T = 7 \text{ Nm} \pm 10\%$,
material number **R913000064**

Pipe thread (G..) to ISO 228/1

Notes

Bosch Rexroth AG
Hydraulics
Zum Eisengießer 1
97816 Lohr am Main, Germany
Phone +49 (0) 93 52 / 18-0
Fax +49 (0) 93 52 / 18-23 58
documentation@boschrexroth.de
www.boschrexroth.de

© This document, as well as the data, specifications and other information set forth in it, are the exclusive property of Bosch Rexroth AG. It may not be reproduced or given to third parties without its consent.

The data specified above only serve to describe the product. No statements concerning a certain condition or suitability for a certain application can be derived from our information. The information given does not release the user from the obligation of own judgment and verification. It must be remembered that our products are subject to a natural process of wear and aging.

Notes

Bosch Rexroth AG
Hydraulics
Zum Eisengießer 1
97816 Lohr am Main, Germany
Phone +49 (0) 93 52 / 18-0
Fax +49 (0) 93 52 / 18-23 58
documentation@boschrexroth.de
www.boschrexroth.de

© This document, as well as the data, specifications and other information set forth in it, are the exclusive property of Bosch Rexroth AG. It may not be reproduced or given to third parties without its consent.

The data specified above only serve to describe the product. No statements concerning a certain condition or suitability for a certain application can be derived from our information. The information given does not release the user from the obligation of own judgment and verification. It must be remembered that our products are subject to a natural process of wear and aging.

Notes

Bosch Rexroth AG
Hydraulics
Zum Eisengießer 1
97816 Lohr am Main, Germany
Phone +49 (0) 93 52 / 18-0
Fax +49 (0) 93 52 / 18-23 58
documentation@boschrexroth.de
www.boschrexroth.de

© This document, as well as the data, specifications and other information set forth in it, are the exclusive property of Bosch Rexroth AG. It may not be reproduced or given to third parties without its consent.

The data specified above only serve to describe the product. No statements concerning a certain condition or suitability for a certain application can be derived from our information. The information given does not release the user from the obligation of own judgment and verification. It must be remembered that our products are subject to a natural process of wear and aging.